

# PQI

Product  
quick info

## siegling belting

NEW



## Belt scraper white (Dual durometer design)

### Applications

- Food industry
- Remove product residues
- Cleaning of the belt surface

### Properties/Advantages

- Unique dual durometer design:
  - =>rigid scraper body/no additional support needed
  - =>soft scraper lip/excellent cleaning result also in combination with soft surfaces, preventing material from re-entering the system
- Highly wear resistant
- Minimal stress on the belt joint
- Longer life of belt and splice
- Compliant to FDA and EU regulations

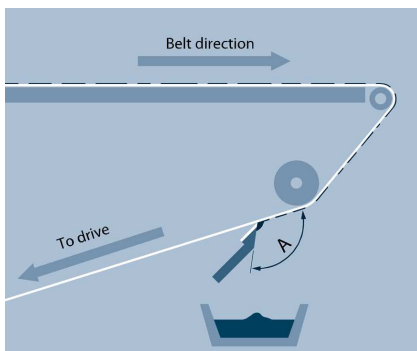
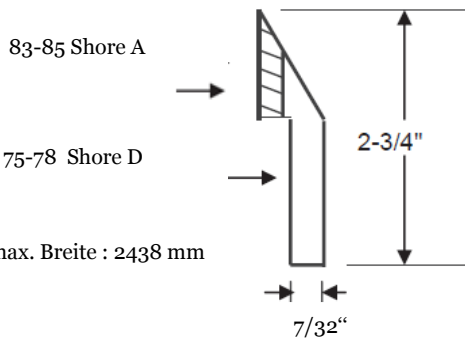

Scraper should lightly touch the belt on the return side just after product has been discharged. The angle "A" normally will be between 100 and 120 degrees.

### Basic technical data

Article no.	882156
Material	urethane
Hardness scraper body [Shore D]	75-78
Hardness scraper lip [Shore A]	83-85
Colour	white
Max. width [mm]	2438
Food grade	FDA, EU
Max. temperature [°C]	83

Product Quick Info 882156-2 - 04/13

FMS - Reproduction of text or parts thereof only with our approval.

Modifications reserved.

Forbo Siegling GmbH

Lilienthalstraße 6/8, D-30179 Hannover

Telefon +49 511 67 04 0, Fax +49 511 67 04 305

www.forbo-siegling.com, siegling@forbo.com

Siegling – total belting solutions

Forbo

MOVEMENT SYSTEMS